

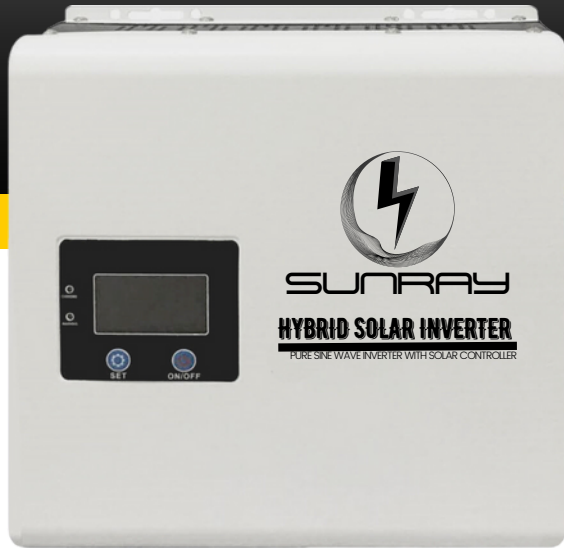

# SMALL SOLAR INVERTER



**Efficiency Range: 88-95%**  
According to operating conditions



## FEATURES AND FUNCTION

- AC Charging current 20A --High-low voltage protection -- Against Overload, short, circuit protection
- Over voltage, battery reverse connection (Optional) -- Under Voltage and over-- Temperature Protection
- Selectable battery priority our utility priority -- Have UPS function and Ac Charge function -- Pure Sine Wave Option

## APPLICATION ON SOLAR ENERGY SYSTEMS

This is a pure sine wave inverter with AC charge and solar controller, LCD display offer users-configurable and clear data. Easy-to-operate- button operation such as battery or city power priority, battery voltage, load, input and output voltage query. It can use for solar power system, light, radio, DVD, TV set and the other house appliance.

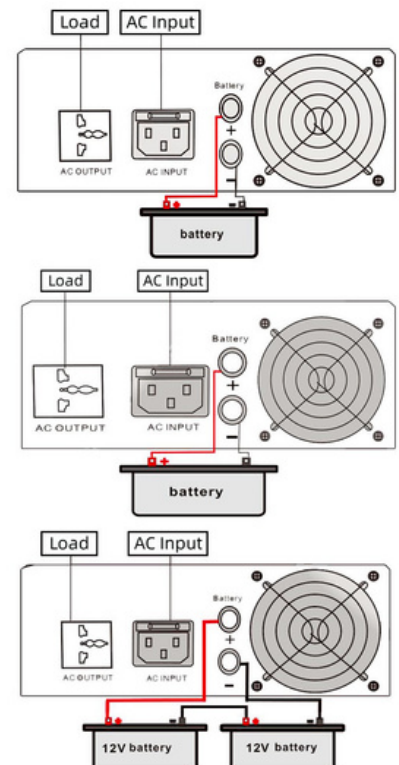
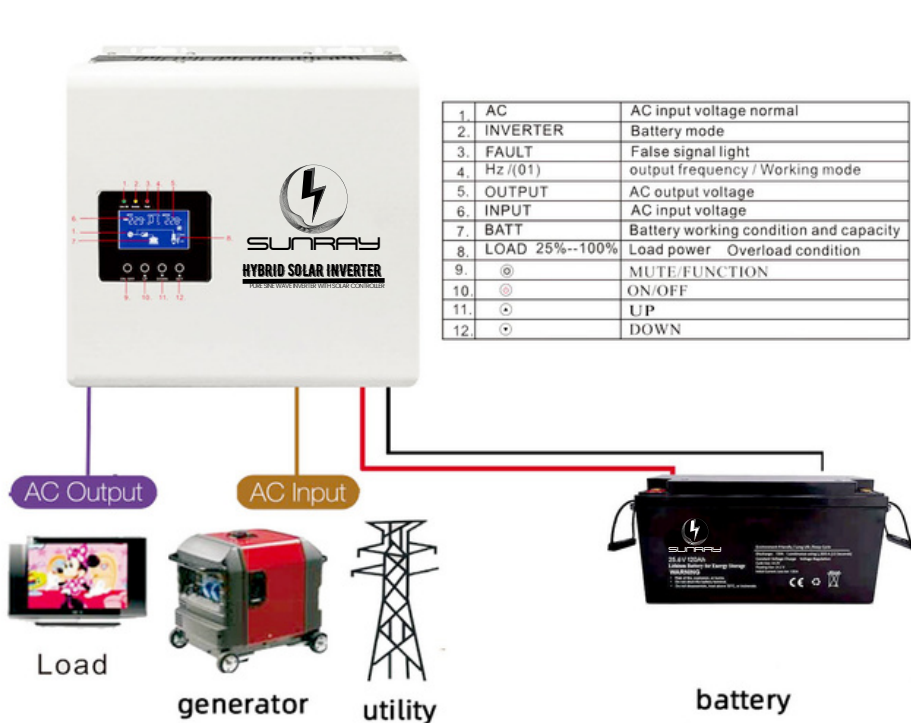

# SPECIFICATION

Model	300W	500W	700W	800W	1000W	1200W	1500W
Rated Power	300W	500W	700W	800W	1000W	1200W	1500W
Peak Power	600W	1000W	1400W	1600W	2000W	2400W	3000W
AC Input Voltage Range	70V-135VAC(110VAC/120VAC)		140V-275VAC(220VAC/230VAC)				
Input Frequency Range	45-65HZ						
Battery Voltage	12VDC/24VDC						24VDC
DC Voltage	12VDC : 10.5-15VDC/24VDC : 21-30VDC						
Battery Undervoltage Alarm	10.5 VDC/ 21 VDC						
Battery Undervoltage	10 V (10-10.9V)						
Battery Overvoltage Protection	16.7V ± 0.5V/ 33.4V ± 0.5V						
Voltage Overvoltage Alarm	15V - 16V/30V - 32VDC						
Overload Protection	Rated Power of 110% or more						
Temperature Protection	≥ 85°C alarm, ≥ 90°C off the machine						
Inverter Output Voltage	110VAC/120VAC/220VAC/230VAC/230VAC ±2%						
Inverter Output Frequency	50/60HZ ± 10%						
Inverter Output Waveform	Pure sine wave						
AC Output Voltage Range	AVR Output 110VAC/120VAC/220VAC/230VAC ± 10%						
Output Frequency Range	Automatic Tracking						
Conversion Time	5ms - 10ms						
Conoling Method	Intelligent fan control, ≤42°C fan slow working, ≥45°C fan high working						
AC Charge Current	15A						
External Size (mm) DxWxH	290 x 310 x 135 mm						
Packing Size (mm) DxWxH	380 x 370 x 450 mm						
Net Weight (Kg)	11	13	14	16	18	20	22
Gross Weight (Kg)	13	15	16	18	20	22	24

# SPECIFICATION

## Working Model Selection

### FREE TO CHOSE (SET)

#### 01: AC priority/City power priority:

When city power is available, the inverter will work AC output, city power will supply power to appliances. The city power and sun power will charge 2 kinds power to battery. When city power failed, sun power will charges the battery and use battery power (solar power) to take the appliances.

#### 02: Energy Saving Model

Load power  $\leq$  10% off the machine.  $\geq$ 11% - 110% turn on.

#### 03: Battery priority

When it have sun power, sun power charges the battery and supply power to the appliance. When it does not have sun power or battery voltage  $\leq$  10.5V, inverter will automatic use city power to take the appliances. When de battery voltage reach 13V inverter will use battery power and sun power.