

**PRETUL®**

CÓDIGO: 21454 CLAVE: VER-6P

**Vernier de 5", Pretul**

- Cuerpo de acero
- Para medir diámetros externos, internos y profundidades

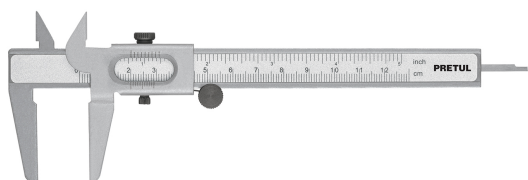

Diámetro externo

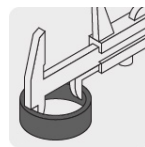

Diámetro interno

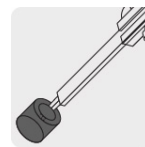

Profundidad

**Certificaciones y garantías****Especificaciones**

<b>Vernier</b>	Escolar
<b>Tolerancia</b>	0.158" / 0.4 mm
<b>Capacidad máxima</b>	5" / 127 mm
<b>Dimensiones (largo x ancho)</b>	18.8 x 1.56 cm
<b>Peso</b>	70.8 g
<b>Empaque individual</b>	Blíster
<b>Inner</b>	6
<b>Master</b>	72
<b>Pallet</b>	2880

**País de origen****Fabricado en China bajo las estrictas especificaciones de GRUPO TRUPER**

**Imagenes complementarias**

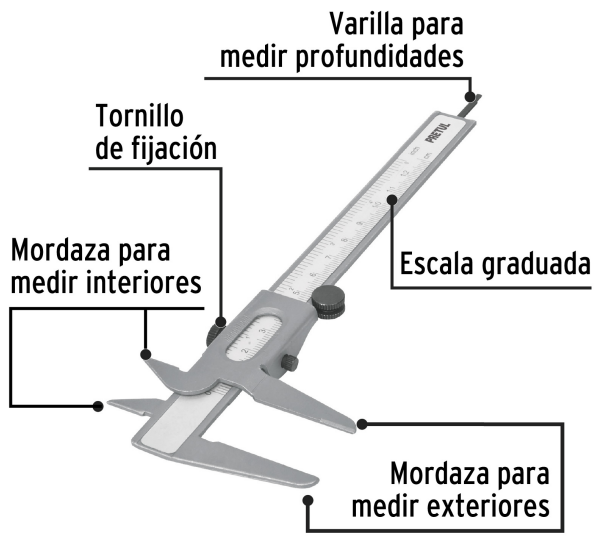

A: Largo total 18.8 cm  
 B: Ancho 15.6 mm  
 C: Alto de la mordaza interior 12.4 mm  
 D: Alto de la mordaza exterior 31 mm

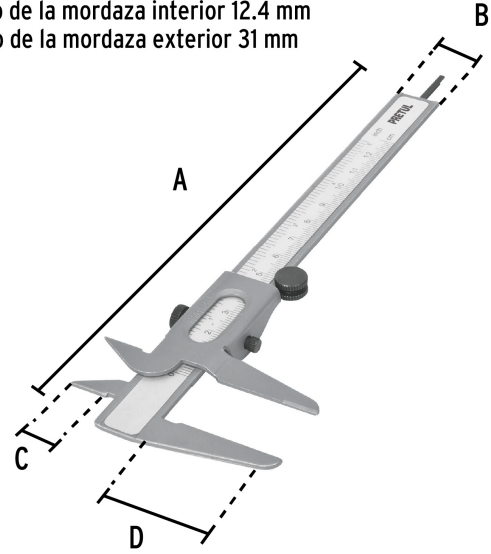

**EMPAQUE INDIVIDUAL**



Alto:  
25.6 cm  
(10")

Largo:  
9.6 cm  
(4")

Peso: 0.09 kg (0.2 lb)

**EMPAQUE INNER**



Alto:  
7.5 cm  
(3")

Ancho:  
10.6 cm  
(4")

Largo:  
26.6 cm  
(10 1/2")

Contiene: 6 piezas

Peso: 0.62 kg (1.3 lb)

## Imágenes complementarias

## EMPAQUE MASTER



Contiene: 12 inner (72 piezas)

Peso: 8.06 kg (17.8 lb)

